

LINE PROPERTIES

**DOUBLE HEAD AUTOMATIC
CABLE SPOOL WINDING LINE**

Developed for spooling of
round/flat type cables,
diameter from 3 - 14 mm.

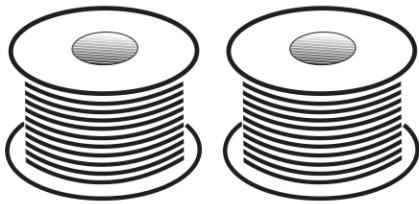

CONFIGURATION

**A. Reelmatik 350D Double Head
Spooler and stretching unit**

- . ± %0,15 length tolerance
- . Improved laying up
- . Variable spool diameter and height
- . Siemens SIMOTION control system
- . Continuous spark and lump/
neckdown control

B. DM 1600 Motorized Pay-off

- . Maximum spool outer diameter : 1600 mm
- . Minimum spool inner diameter : 800 mm
- . Maksimum reel height : 2.5 ton

C. Spool exit conveyor

Spool Dimension;

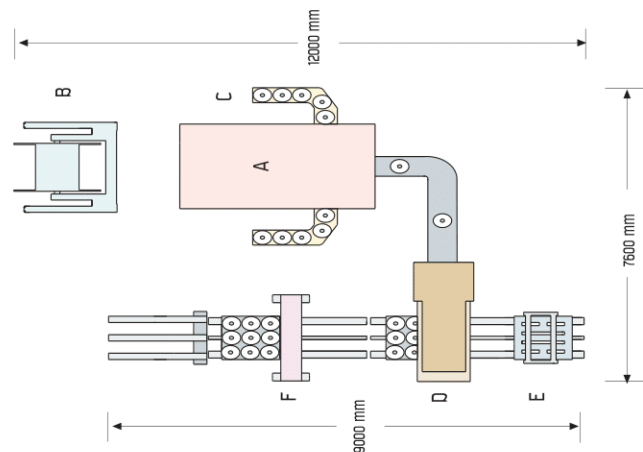
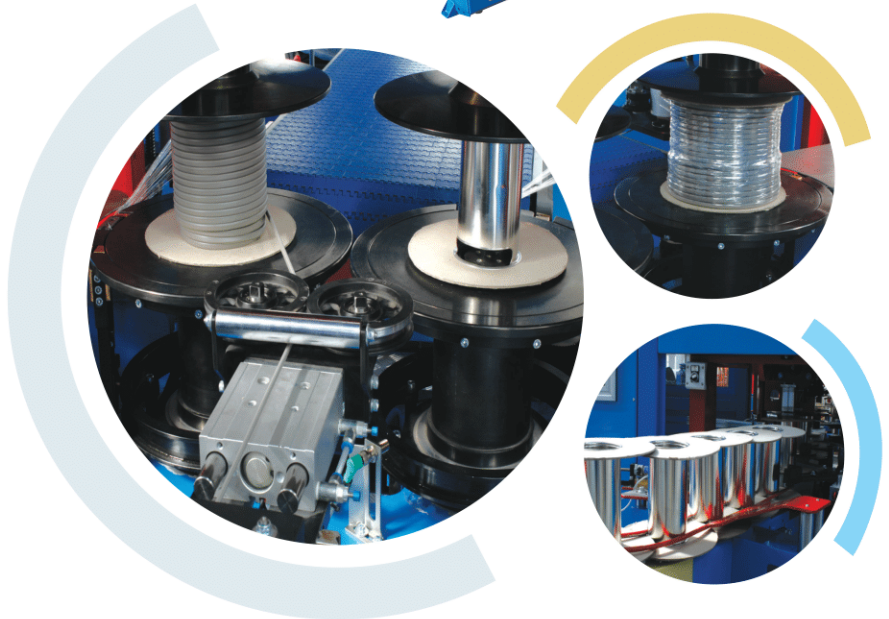
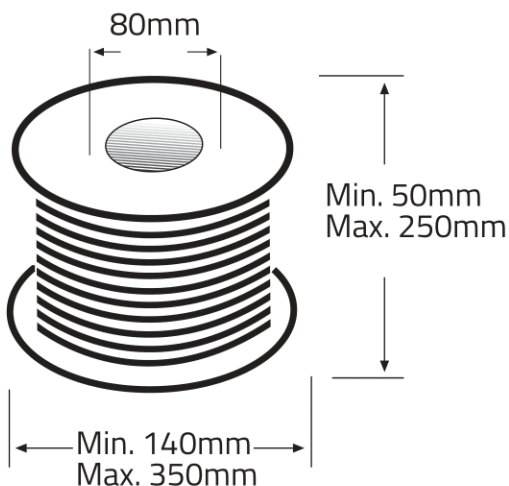

● CABLE TYPE

1. Rigid, flexible and multi stranded single core cable spooling from 1,5 up to 16 mm²
2. Flexible or rigid multi core from 2x0,75 up to 4x2,5 mm²
3. Flat twin and earth type cable from 2x1+1 up to 2x4+2,5 mm²

